



BluEnergy
Revolution

BLUENERGY REVOLUTION: OPPORTUNITÀ ED ESPERIENZE IN AMBITO IDROGENO

ANDREA GIUGNO

Project Manager, BluEnergy Revolution



BluEnergy
Revolution

- *System integrators*
- *Hydrogen projects*
- *Product developers*
- *Hydrogen tech specialists*
- *Hydrogen R&D*

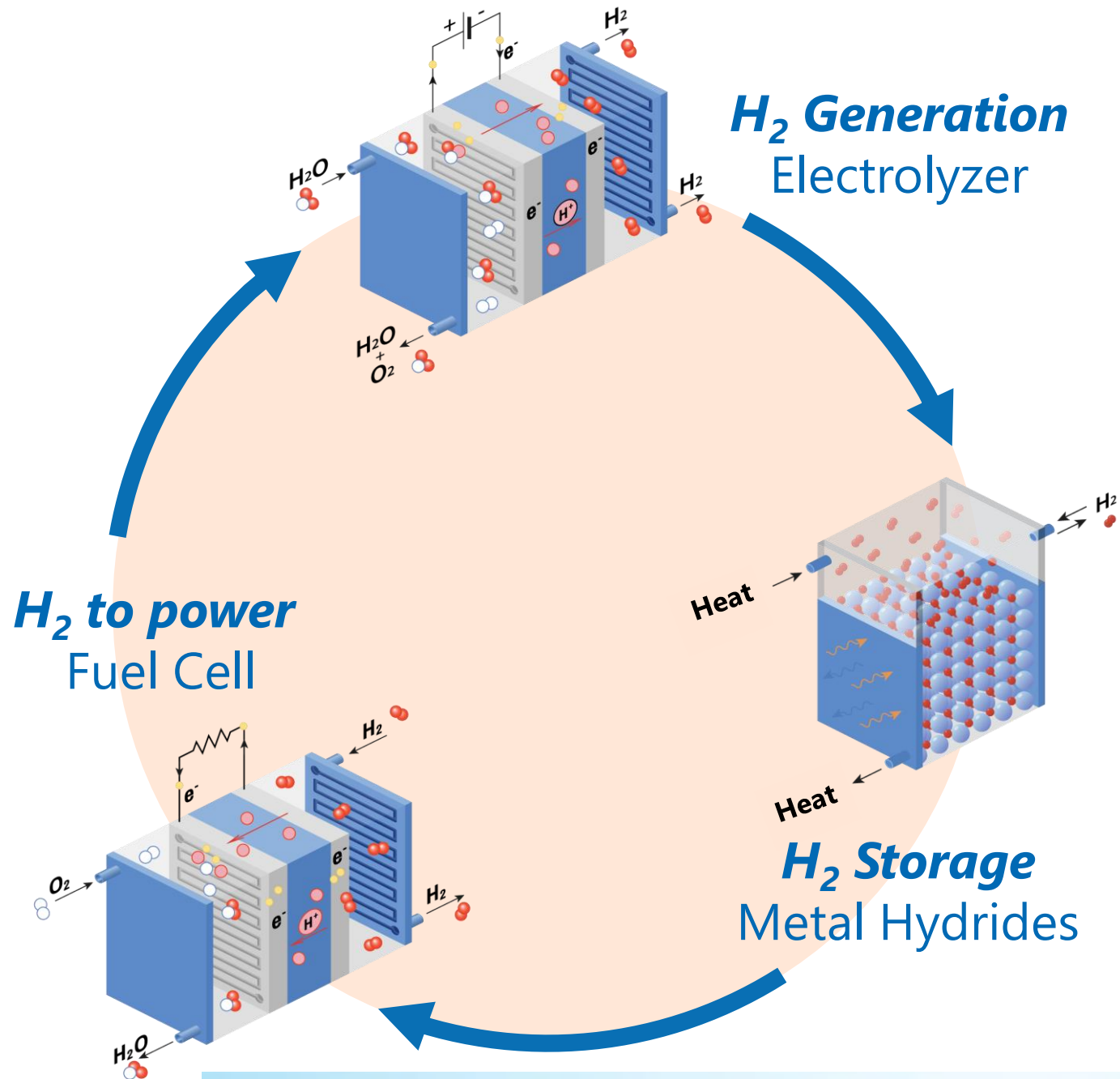



BluEnergy
Revolution

for the BIIM project

2021-2024: BIIM project

Battello Ibrido ad Idrogeno Modulare

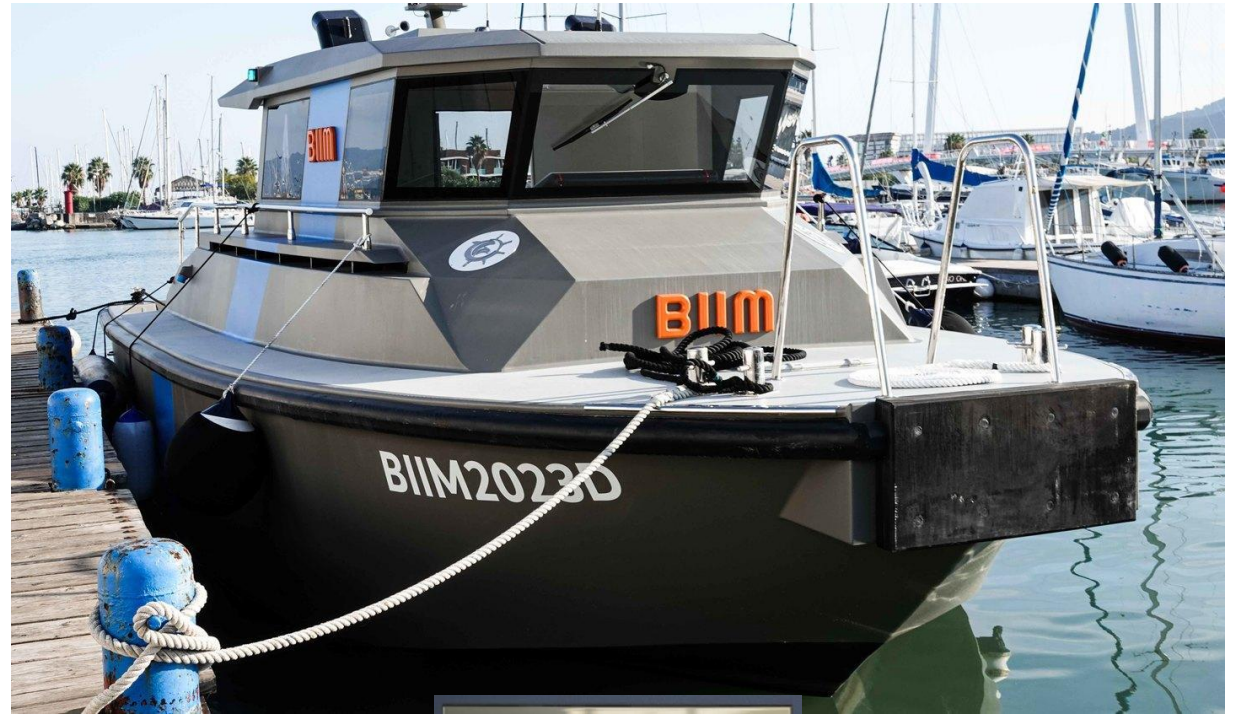

45 kW Fuel Cell

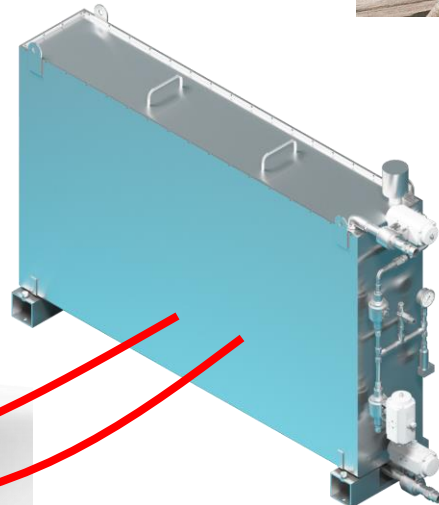
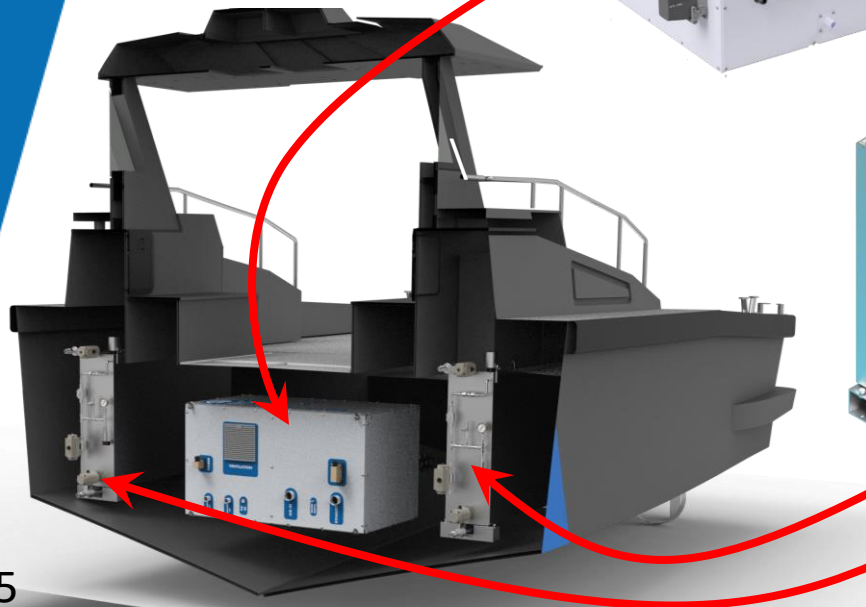

2 x Metal hydride Storage unit
(7 kg H₂ storage)

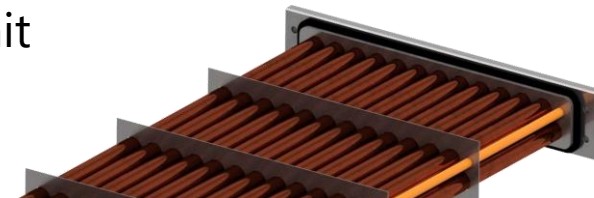

03/10/2024 Webinar "Idrogeno verde e Competenze per le PMI: Le Opportunità di EEN e H2Excellence"



BluEnergy
Revolution

for our customer



BAGLIETTO
1854

2022-2024: Baglietto

Electrolyzers and H₂ Storage system integration



03/10/2024 Webinar "Idrogeno verde e Competenze per le PMI: Le Opportunità di EEN e H2Excellence"



BluEnergy
Revolution

for our customer



ENPHOS



1 MW PEM Electrolyzer
preliminary design

2023-2024: 160 kW PEM Electrolyzer
design and installation



03/10/2024 Webinar "Idrogeno verde e Competenze per le PMI: Le Opportunità di EEN e H2Excellence"

2023-2024: SITAV

Fuel Cell Power system for the railway sector



BluEnergy
Revolution

for our partner

SITAV
Società Italiana Treni Alta Velocità

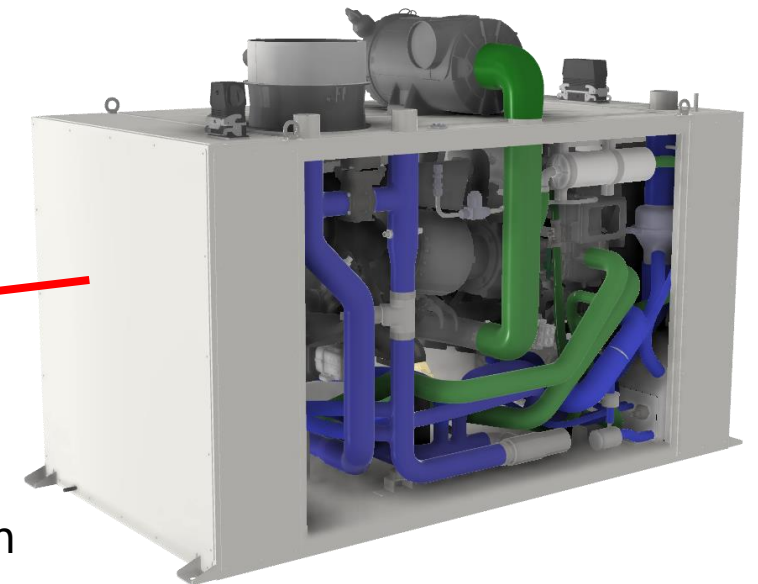
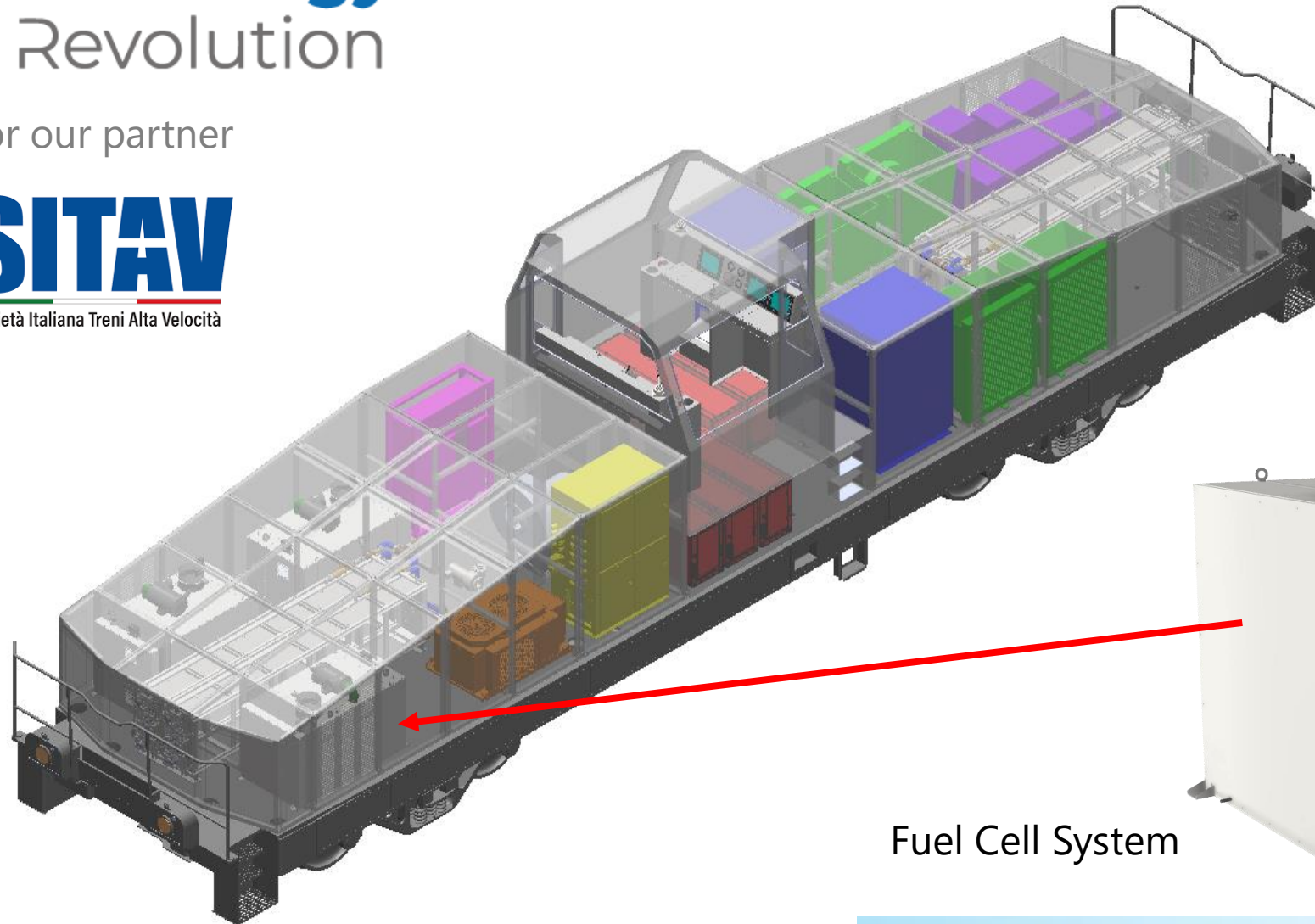

Fuel Cell System

Shunting locomotive equipped with H₂ technologies

03/10/2024 Webinar "Idrogeno verde e Competenze per le PMI: Le Opportunità di EEN e H2Excellence"

2021-2024: MOSE 7 kW PEM Electrolyzer prototyping, design and product development

👉 CE marking ongoing!



MOSE

⚡ MODULAR
SMART
ELECTROLYZER



Product preseries launch: April 2023

First product installation: November 2024

03/10/2024 Webinar "Idrogeno verde e Competenze per le PMI: Le Opportunità di EEN e H2Excellence"



BluEnergy
Revolution

2023-2024: Regenerative Dryer Product

CE marking pending

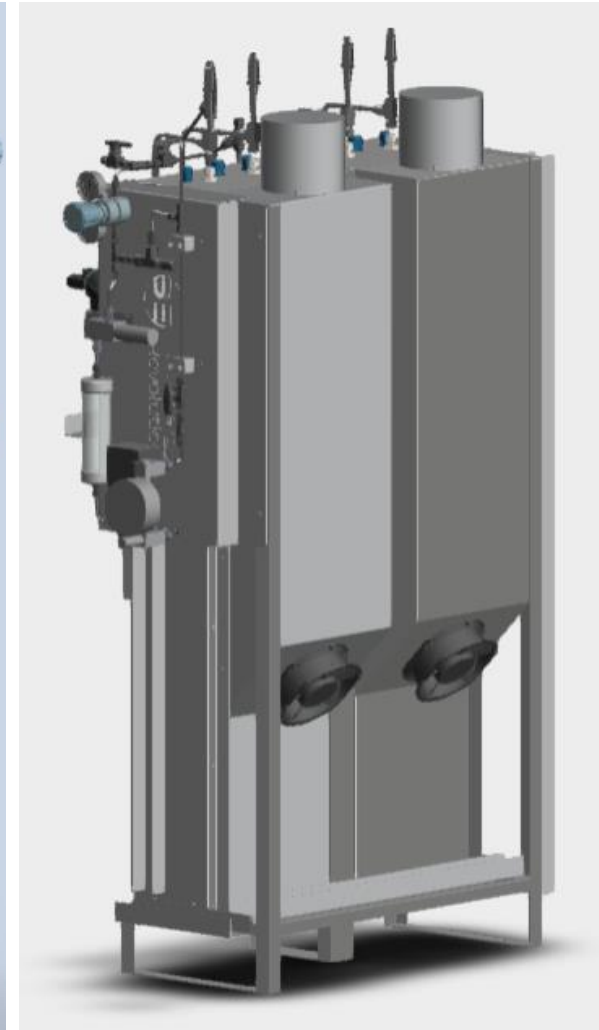
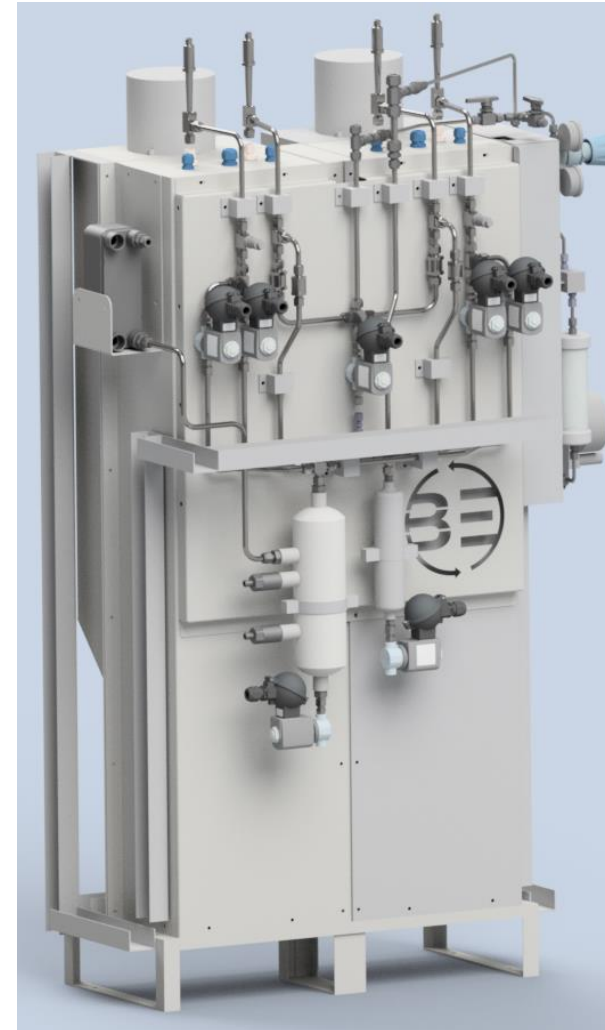
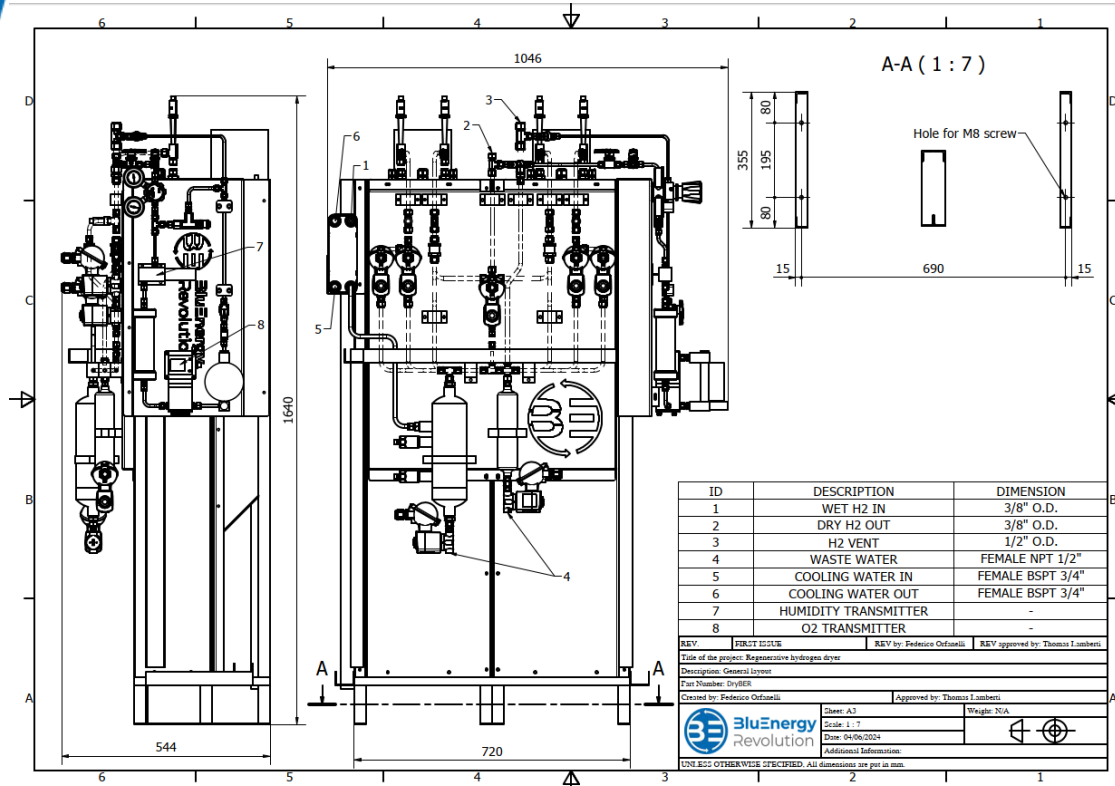

03/10/2024 Webinar "Idrogeno verde e Competenze per le PMI: Le Opportunità di EEN e H2Excellence"



BluEnergy
Revolution

BER ENERGY PACK

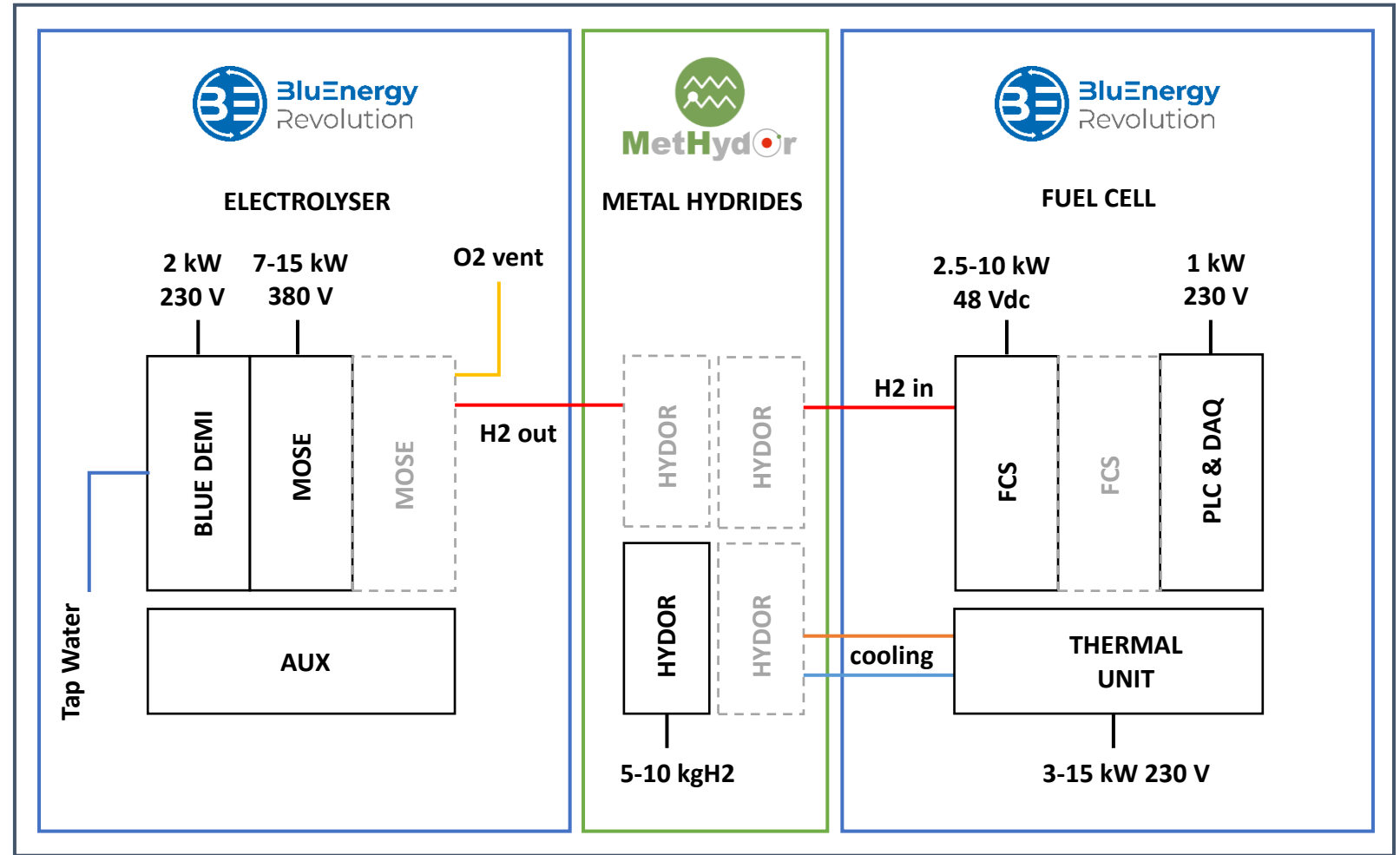

10 ft
Container

VERSION A
WITH EXTERNAL ACCESS TO TECHNICAL AREA

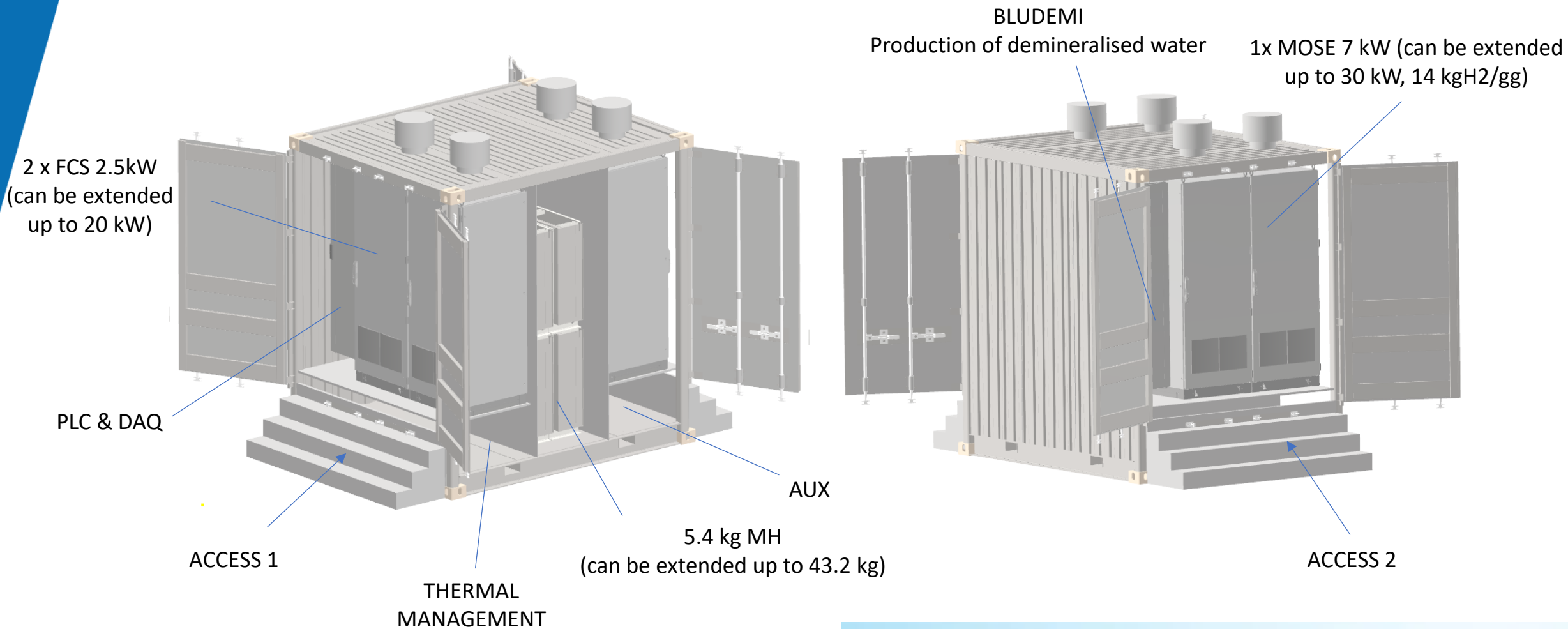



BluEnergy
Revolution

- ***System integrators***
- ***Hydrogen projects***
- ***Product developers***
- ***Hydrogen tech specialists***
- ***Hydrogen R&D***

Thank you for your attention!



We are fully committed to a H₂ mission since 2015